



Design and Implementation of a Fuzzy Logic Controller for Power Plant Temperature Monitoring and Control using Fuzzylite

F. I. David^{1*}, K. A. Akpado¹ and T. L. Alumona¹

¹Department of Electronics and Computer Engineering, Nnamdi Azikiwe University, Awka, Nigeria.

Authors' contributions

This work was carried out in collaboration between all authors. Author FID designed the study, performed the statistical analysis, wrote the protocol, and wrote the first draft of the manuscript. Author KAA design and supervised the study, edit the final draft of the manuscript and Author TLA managed the literature review, also took part in the analysis of the data. All authors read and approved the final manuscript.

Article Information

DOI: 10.9734/JERR/2021/v20i617325

Editor(s):

(1) Dr. David Armando Contreras-Solorio, Autonomous University of Zacatecas, Mexico.

Reviewers:

(1) Peter Anuoluwapo Gbadega, University of KwaZulu-Natal, South Africa.

(2) S. Ramabalan, E.G.S. Pillay Engineering College, India.

Complete Peer review History: <http://www.sdiarticle4.com/review-history/67456>

Received 20 February 2021

Accepted 26 April 2021

Published 05 May 2021

Original Research Article

ABSTRACT

Design and implementation of a fuzzy logic controller for power plant temperature monitoring and control used fuzzy lite software to simulate using triangular method and compared with bell shape membership function. Fuzzy logic technology was deployed; the motor temperature and RPM being used as crisp inputs to the fuzzy logic controller with appropriate membership function definitions. The fuzzy logic was designed and simulated using the Fuzzy Lite and Proteus software. It was implemented as firmware written in C++ programming language being executed on the PIC16F877A microcontroller. The results gotten from the simulations and implementation were in concordance as variations in motor temperature influenced motor speed. Triangular method used in this work was compared with Bell shape method used in previous work to ascertain its contribution to knowledge and also discovered that triangular method is more precise in its result.

Keywords: Power plant; temperature monitoring; fuzzylite; fuzzy logic controller.

*Corresponding author: Email: fi.david@unizik.edu.ng;

1. INTRODUCTION

The need for control arises in various fields such as medical, biological, undersea, industrial and in basic scientific research. Chemical and physical reactions are sensitive to temperature; hence temperature control is important in many industrial processes. In many applications, temperature control plays a key role in processes; in addition, precision and quality control of temperature (with minimum overshoots and undershoots, fast rise and settling times) is desirable [1].

A mathematical model is required for classical control theory for designing the controller. For nonlinear and complex control systems, inaccurate mathematical modeling of the system usually degrades the performance of the controller [2]. Hence, this article studies the application of fuzzy logic for power plant monitoring and control with emphases on temperature.

Recently, the advent of the fuzzy logic controllers (FLCs) has inspired new resources for the possible realization of better and more efficient control. Fuzzy control which is based on human expert decision making do not require mathematical model of the plants and is dominant for process control applications [3]. Hence, this article studies the application of fuzzy logic for power plant monitoring and control with emphases on temperature monitoring and control.

A power plant which is also known as a power station or power generating station is an industrial plant used for the generation and distribution of electric power on a mass scale. Power stations are made up off one or more generators, a rotating machine that converts mechanical power into three-phase electric power (alternator).

A plant is a collection of electrical or mechanical equipment used in carrying out an industrial activity. It is also referred to as a machine. Every plant/machine has several parts and equally requires power to be operated [4]. Power plants are generally located in several kilometers away from the cities or the sub-urban regions because of its huge land requirement, water demand and several operating constraints like waste disposal etc. For this reason, a power generating station does not only concern itself with the efficient generation of power, but also in the transmission

of this power. This is why transformer switchyards are often built close to power plants. These way the switchyards increases the transmission voltage of the power, this make it to be more efficiently transmitted over long distances [5].

SMS based control requires that the plant will send the values of critical parameters like temperature as SMS to the phone number of the operator. Hence, he does not need to be in the same physical location as the machine in other to monitor the temperature. To control the machine, the operator sends SMS to the machine. The machine receives and interprets the SMS and carries out the control instruction as written in the received SMS [6].

In the case of plant monitoring and control system using SMS which this project implemented, the above-mentioned concepts and trends come to play. A device must monitor the activities of another device; probably control it to the advantage of man. To achieve this, both devices (the one controlling and the one being controlled) must be embedded systems. They must have the ability to process data, and to communicate so that internet of things (IOT) can be implemented [7].

It will also be advantageous that ubiquitous devices like the GSM phone is used. It follows that both devices must communicate by sending and receiving SMS so that the user of the phone can easily see and monitor the parameters of the plant [8].

This project, design and implementation of a fuzzy logic controller for power plant temperature monitoring and control will utilize this concepts and trends to allow the operator to monitor and control a plant/machine remotely even when he is not physically present at the site by sending SMS using his phone and getting an SMS response from the plant/machine telling the operator what it has done.

To achieve this, a gas turbine has many components, the turbine, generator, electric motor etc. In this work we considered electric motor since temperature places a very vital role in the overall operation of the system.

1.1 Review of Electric Motor

Electrical energy is converted to mechanical energy using electrical machine called electric

motor. A force is generated in the form of rotation of a shaft when there is an interaction between the motor's magnetic field and electric current in the coil winding.

Electric motors can be powered by direct current (DC) sources, such as from batteries, motor vehicles or rectifiers, or by alternating current (AC) sources, such as a power grid, inverters or electrical generators. An electric generator is mechanically identical to an electric motor, but operates in the reverse direction, converting mechanical energy into electrical energy. The principle of working of an electric motor is that "whenever a current carrying conductor is placed

in a magnetic field, it experiences a mechanical force" [9].

Fleming's left-hand rule is used to determine the direction of the force and its magnitude is given by

$$F = BIL \text{ equation 1.1}$$

Where,

B = magnetic flux density,

I = current and

L = length of the conductor in the magnetic field.

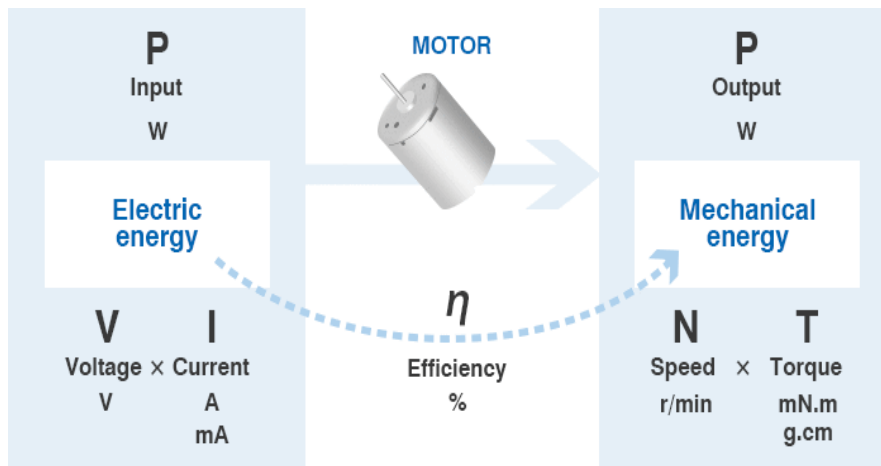

Fig. 1. Basic structure of electric motor

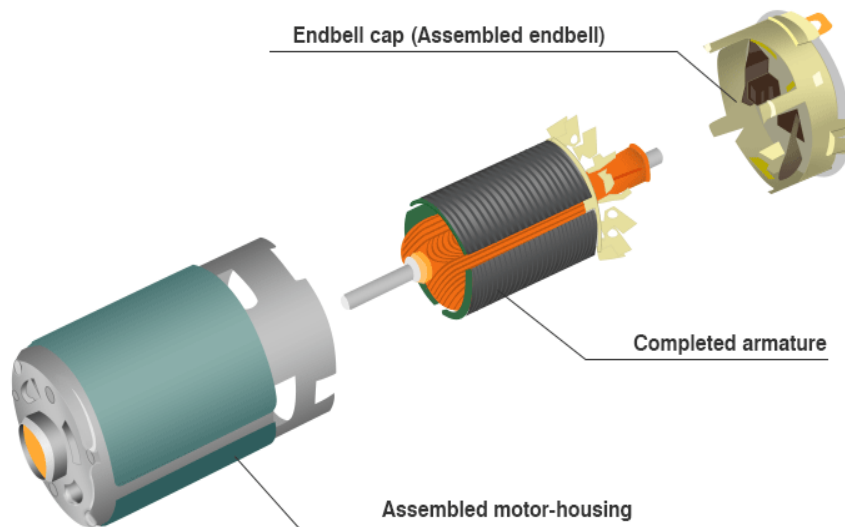

Fig. 2. Diagram of electric motor

1.2 Gas Turbine

The gas turbine is the major engine in a power plant use to produces electric current. A gas turbine is a combustion engine use to convert natural gas or other liquid fuels to mechanical energy. The energy is use to drive a generator that produces electrical energy [10].

A simple gas turbine comprises of three main sections, a combustor, a compressor, and a power turbine. The gas-turbine operates on the principle of Brayton cycle, compressed air is mixed with fuel inside the gas turbine and burned under constant pressure conditions. The hot gas produced is allowed to expand in a turbine to perform work [3].

Electricity generation is achieved when the gas turbine heats up a mixture of air and fuel at a very high temperature, thereby cause the turbine blade to spin. The spinning of the turbine then drives a generator that converts the energy into electricity. A combine cycle power plant can be deployed to create power efficiently by using the combination of a gas and steam turbine. The electricity generation process involves the following procedures [11]:

1. Air-fuel mixture ignites: The gas turbine compresses air and mixes it with fuel that is then burned at extremely high temperatures, creating a hot gas.
2. Hot gas spins turbine blades: The hot air-and-fuel mixture moves through blades in the turbine, causing them to spin quickly.

3. Spinning blades turn the drive shaft: The fast-spinning turbine blades rotate the turbine drive shaft.
4. Turbine rotation powers the generator: The spinning turbine is connected to the rod in a generator that turns a large magnet surrounded by coils of copper wire.
5. Generator magnet causes electrons to move and creates electricity: The fast-revolving generator magnet creates a powerful magnetic field that lines up the electrons around the copper coils and causes them to move. The movement of these electrons through a wire is called electricity.

The use of gas turbine to generate electricity date back to 1939. Today, the technology most widely used to generate electricity is gas turbines. Burning of air-fuel mixture produces hot gases that spin a turbine to produce power using gas turbine as a type of internal combustion (IC) engine. The name gas turbine is gotten from the production of hot gas during fuel combustion, not the fuel itself that gives gas turbines the name. A variety of fuels, including natural gas, fuel oils, and synthetic fuels can be used on gas turbine. In IC engines, combustion occurs intermittently while combustion occurs continuously in gas turbine [6].

1.2.1 Operation of gas turbine

Gas turbines are theoretically simple, and have three main parts as seen in Fig. 3.

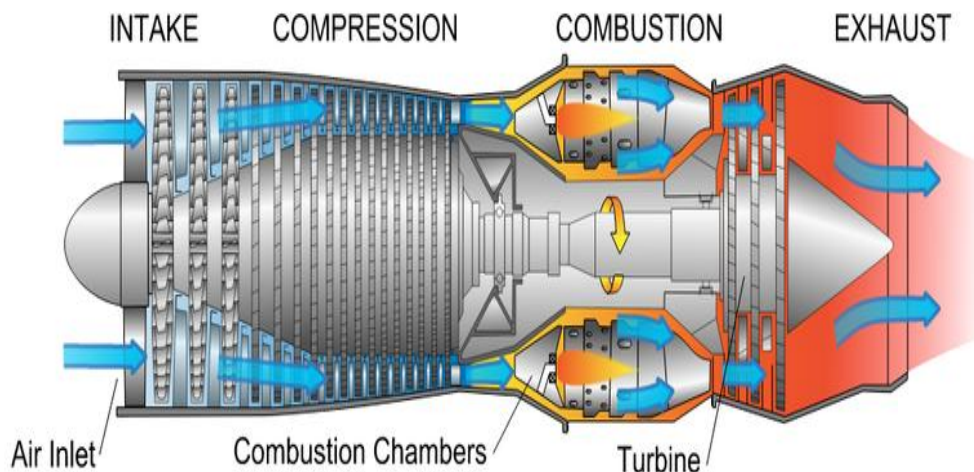

Fig. 3. Diagram of gas turbine engine

1.2.2 Compressor

It takes in air from the environment of the turbine and compresses it to increase its pressure. In FigS 1.3 air is sucked in from the air inlet to the compressor which consists of many rows of fan blades. The pressure of the air can increase by a factor of 30 in some turbines.

1.2.3 Combustor

In the combustion chambers, the fuel burns and produces high pressure and high velocity gas. The high-pressure air flows into the combustor, where the fuel is introduced. The fuel is injected constantly to maintain constant energy to the turbine.

1.2.4 Turbine

A turbine extracts its energy from the compress gas from the combustor. A shaft connects the turbine to the compressor blades, but they spin separately. The compressor is connected to the turbine which in turn is connected to an output shaft, it can get up to very high speed due to the hot gas flowing through it because the turbine spins separately.

A compressor can either be centrifugal or axial flow type. For higher flow rate and efficiency, axial flow compressors are more common in power generation. Axial flow compressors, comprises of multiple stages of stationary blades (stators) and rotating blades through which air is drawn in parallel to the axis of rotation and gradually compressed as it passes through each stage. Diffusion by the stators and acceleration of the air through the rotating blades reduces the volume and increases the pressure of the air. Even though no heat is added, the compression of the air also causes the temperature to increase [4].

1.3 Fuzzy Logic Technology

Particularly in control applications, fuzzy logic has emerged as one of the active areas of research activity. Fuzzy logic is a powerful method of reasoning when mathematical models are not available and input data are imprecise [12]. Fuzzy logic applications, are being studied throughout the world by control engineers. Fuzzy logic is indeed a powerful control tool as study have shown, when it comes to control systems or processes which are complex. Some studies have also shown that the fuzzy logic performs

better when compared to conventional control mechanisms like PID. Wherever logic in the spirit of human thinking can be introduced, fuzzy logic finds extreme application there [3].

1.3.1 Fuzzy sets vs. crisp sets

The main objective of fuzzy logic is to represent some particular form of knowledge expressed in a linguistic form. One has to build a conceptual framework to tackle inherent vagueness when using a language-oriented approach for knowledge representation.

The crisp sets are based on a two-value logic: objects are either members or not members of the set. Every individual object is assigned a membership value μ of either 1 or 0 that discriminates between members and non-members of the crisp set [2].

For example, the crisp set High in terms of temperature may be defined such that:

$$\mu_{\text{High}} = \begin{cases} 0 & \text{if } T < 30^\circ \text{C} \\ 1 & \text{if } T \geq 30^\circ \text{C} \end{cases} \quad 1.2$$

where T is the actual temperature. High is a Linguistic Variable that describes member of a set. The membership function μ_{High} is the measure of "belongingness" to the category of High. If $T = 50^\circ\text{C}$, $\mu_{\text{High}}(50^\circ\text{C}) = 1$, and the temperature is 100% high and definitely not low.

Fuzzy-set theory on the other hand, is based on multivalued logic, and deals with the concepts that are not sharply defined. In fuzzy logic membership the Linguistic variable High may be defined as:

$$\mu_{\text{High}} = \frac{(T - 20)}{10} \begin{cases} 0 & \text{if } 0^\circ\text{C} \leq T < 20^\circ \text{C} \\ 1 & \text{if } 20^\circ\text{C} \leq T \leq 30^\circ \text{C} \end{cases} \quad 1.3$$

if $30^\circ\text{C} < T \leq 40^\circ\text{C}$

1.3.2 Basic function of fuzzy logic controller

A fuzzy logic base control system has a fuzzy inference and a knowledge-base. The fuzzy inference engine is executed periodically to determine system output based on current system input. The knowledge-base contains membership functions and rules [13].

A programmer who does not know how the application works can write a fuzzy inference engine. A fuzzy inference engine generates

system output signals in response to current system input conditions once “execution pass” through, [2].

1.3.3 The fuzzy logic control system

Fuzzification implies the process of transforming the crisp values of the inputs to a controller to the fuzzy domain. The fuzzified values (input), then fire the rule base to generate fuzzified output. As a final step, the fuzzified output is defuzzified to yield the crisp controller output [2].

- (i). Fuzzification: Usually in a program loop structure, to determine the degree to which each linguistic variable of each system is true, the current input values are compared with stored input membership functions.
- (ii). Rule Evaluation: Processes a list of rules from the knowledge-based using current fuzzy input values to produce a list of fuzzy output linguistic variable.
- (iii). Membership function Fuzzy Output: Considers raw suggestions for what the system output should be in response to the current input conditions.
- (iv). Defuzzification: This is a process of producing a crisp logic output from a fuzzy set and corresponding membership degree from the system. It maps a fuzzy set to a crisp set.

1.4 The Future Trend

The question now is could the burgeoning internet of things (IoT) provide an answer? IoT which aim to add intelligence and connectivity to almost any device or machine, is envisioned by many as a transformative force for change in the manufacturing world; from the introduction of advanced robots in the workplace to smart components that communicate their own assembly instructions to the production line [6].

Remote monitoring is now a more integral part of daily operations in many manufacturing facilities. The newest technology of remote monitoring is associated with lower cost and simpler implementation. Factors driving remote monitoring proliferation have to do with lower initial capital investment costs needed for implementation; others are the result of fewer operators on the plant floor. Remote monitoring facilitates more effective monitoring by fewer personnel, in today’s tough economic climate enable operators to monitor conditions from just about anywhere [14].

Remote monitoring present significant potential benefits: it prolongs equipment life, it minimizes labor costs, it also prevents unplanned downtime, filling the knowledge gap from retired experienced operators and more.

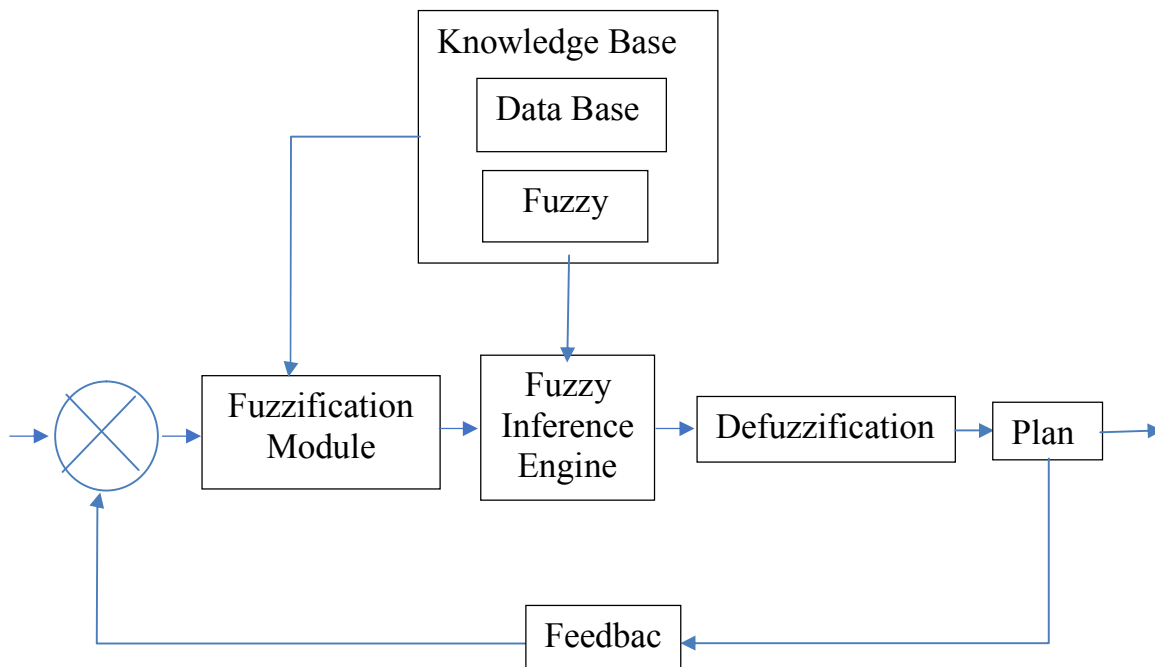

Fig. 4. Fuzzy logic base control system

2. LITERATURE REVIEW

Ying [1] "Advanced Fuzzy Logic Technologies in Industrial Applications" gave insight into fuzzy logic technology in industrial applications which addresses the problem by introducing a dynamic, on-line fuzzy inference system. In this system, not until the system is applied, membership functions and control rules are not determined and each output of its lookup table is calculated based on the value of the current inputs. In conclusion, the fuzzy logic systems provide difference between "on or off" and "yes or no".

Wartsila [4] of Chongqing College of Electronic Engineering "designed and implemented a PLC based industrial temperature control system". In his work, he clearly describes temperature control system as a complex process object involving large inertia and pure delay with multi-variable and time-varying parameters. In this work, the author was able to display temperature control in real-time inside the box. By setting the temperature through a fan and a heating plate, PID control algorithm was introduced to control the temperature of the box to achieve the temperature control needs.

Thomas [5] and Bamidele [6] in a project "fuzzy Logic-Based Induction Motor Protection System", and 'Basic characteristics and mathematical model.' emphasis more on system protection, which is very important to detect abnormal motor running conditions such as over current, over voltage, overload, over temperature, and so on. In this system, a time delay is specified to trip the motor when a failure is sensed by the protection system. In classical systems, motors are stopped with time delay without considering the fault level by constant adjustment. This work presents a fuzzy logic-based protection system detecting faulty operations for a three-phase induction motor.

The author [5] described "the methodology of design and development of fuzzy logic-based oven temperature control system". Designed a simple fuzzy logic controller structure with an efficient result and a small rule base that can be easily implemented in existing underwater control systems was proposed. Bell shape membership function was used for fuzzification, 49 control rules was used in its rule base and canter of gravity technique was used for defuzzification. Experimental validation of the system shows that fuzzy controller is better than PID controller. Fuzzy controller exhibits better response in transient state and the steady state response of

the fuzzy controller is also better compared with the PID controller.

This work by [8] discusses the "performance analysis of a heat exchanger using simulations for an Adaptive Network based Fuzzy Inference System toolbox developed with MATLAB". This research compares the control performance of PID (Proportional Integral and Derivative) and Fuzzy logic controllers. Conclusions are made based on the control performances. The conclusion is that the control performance for a Fuzzy controller is similar to a PID controller but comparatively fuzzy controller gives a better response.

Singh [11] presented "a method based on fuzzy logic controllers (FLCs) for automatic generation control (AGC) of power system including three areas" here two steam turbines and one hydro turbine was tied together on a power line. This study applies FLC to AGC in power system with three areas. The design of the proposed FLC is very simple and effective. In conclusion, since it is a model-free type of controller, it can therefore be implemented to a power system. From the obtained results, it was shown that the performance of Fuzzy-PI controller outperforms that of conventional PI controller at AGC in power system.

PCB-3D [15] discussed "DC motors - Basic characteristics and mathematical model". A plant to be monitored and controlled using SMS must have a means to communicate with an operator by means of SMS. It must have GSM Module, with a sim card inserted, through which it can send and receive SMS. The GSM Module gives the plant access to a GSM network. The SMS to be sent and received must be interpreted and formatted to make sense to the plant and the operator hence a microcontroller is necessary.

Arvind [16] In "fuzzy logic controller for temperature regulation process". FLC was designed for temperature control. The performance of the FLC was evaluated and compared with PID controller. PID controller was tuned by stepwise determining the control parameters. Comparing fuzzy logic controller with conventional PID controller shows that fuzzy logic is better, faster and useful in reaching the set point faster whereas the PID Controller is useful for maintaining the process variable value at the set point. Fuzzy Logic Controllers are much closer in human thinking and decision-making.

Lei [17] talks about “Temperature Control using Fuzzy Logic” The temperature control is aim at heating the system up to the require value, then hold it at that value in an insured manner. Precision control can be accomplished using fuzzy logic controller. For non-linear dynamical system, significant research has been done using fuzzy logic for over twenty years or more. Temperature control system using fuzzy logic was developed. Convention controllers are deducted using control theory techniques. The feedback controller guaranteed the desired response of the output.

Surti [18] this research paper describes “the fuzzy logic temperature control system of the induction furnace”. During the heating process, the temperature requirement of the heating system varies. The change in the load causes the switching losses to increase in a conventional control scheme. For the system to be smooth, a closed loop control is required. In this system, Using the fuzzy logic controller, a pulse width modulation-based power control scheme is developed for the induction heating system. For an efficient response the induction furnace requires a good voltage regulation. Microcontroller is used to implement control in hardware system. The simulation of fuzzy logic controller design is done in MATLAB to get the desire condition.

The author in [19] “Control of Gas Turbine’s speed with a Fuzzy logic controller” For generating substantial power across the globe a gas turbine generator is widely used. Different control algorithms are applied to control the speed of the turbine at different loads. PID control is a control system commonly used and is implemented on a large scale. This paper presents a better and efficient way to control the gas turbine using the application of a Fuzzy logic control algorithm. The system is simulated on MATLAB SIMULINK, making comparison to show effectiveness of the proposed Fuzzy logic control algorithm as compared to the traditional PID control.

3. THE PROPOSED SYSTEM

The proposed system will monitor the temperature of the coils by having an embedded temperature sensor, LM35, implanted in the coil of the motor. This will detect variations in coil temperature and this temperature will serve as the input to a fuzzy logic controller. The de-fuzzified output of the controller will generate

pulse width modulation (PWM) which will be used to control the motor current, hence keeping the temperature of the motor within safe operating range. A Hall Effect sensor A1101 is equally attached to the motor, used to count the motor RPM so as to know the extent of control achieved by the fuzzy controller.

A Global System for Mobile communication (GSM) module is connected to the microcontroller so that the system will have remote monitoring capability as motor operating parameters are sent by SMS to the plant operator. Here, a sim800A GSM module is used. The transmit and receive pins of the GSM module will be connected to a voltage translator IC to ensure that the required voltage level on the serial port of both the microcontroller and the GSM module is within specifications on their datasheets. This system, using the GSM module, then sends SMS to the plant operator specifying the motor parameters. The microcontroller communicates with the GSM module using AT command syntaxes.

Also, there is an LCD used for displaying the temperature and the RPM. Buttons is also made available for human interaction to key in the acceptable temperature range (values).

3.1 The System Block Diagram

The system block diagram is a representation of the complete design system. These are the prominent components and are put together following a block diagram as shown below.

3.2 The Power Supply System

An optimal power supply was developed. This was built using a transformer, rectifiers, filters and voltage regulators. Starting with an AC voltage, a steady DC voltage is obtained by rectifying the AC voltage which after is filtered to a DC level and finally regulated to obtain a desired fixed DC voltage. The regulation is usually obtained from an IC voltage regulator unit, it takes DC voltage and provides sufficient lower DC voltage, which remains the same even if the input DC voltage varies even when the output load connected to the DC voltage changes.

The AC voltage, typically 220 Vrms is connected to a transformer which steps the AC voltage down to the level for the desired DC output (12V).

A diode rectifier then provides a full-wave rectified voltage that is initially filtered by a simple capacitor filtering and smoothing of the DC voltage. The resulting DC voltage usually have some harmonics.

A regulator circuit accepts the harmonized DC voltage as input to provide a DC voltage that has not only much less ripples but also remains the same DC value even if the input DC voltage varies to some extent, or the load connected to

the output DC voltage changes. This voltage regulation is usually obtained using one of the popular voltage regulator IC units (7805 regulator) with outputs of 5v.

3.3 The Circuit Diagram on Proteus

A schematic capturing of the circuit by interconnection of the different modules was done using Proteus for the purpose of simulation.

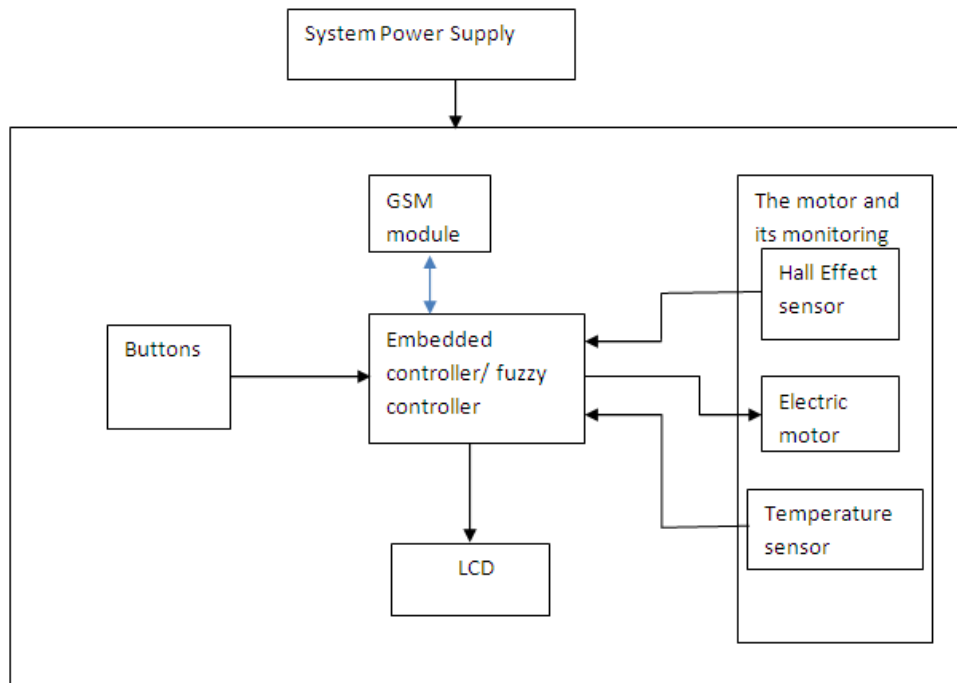

Fig. 5. System block diagram

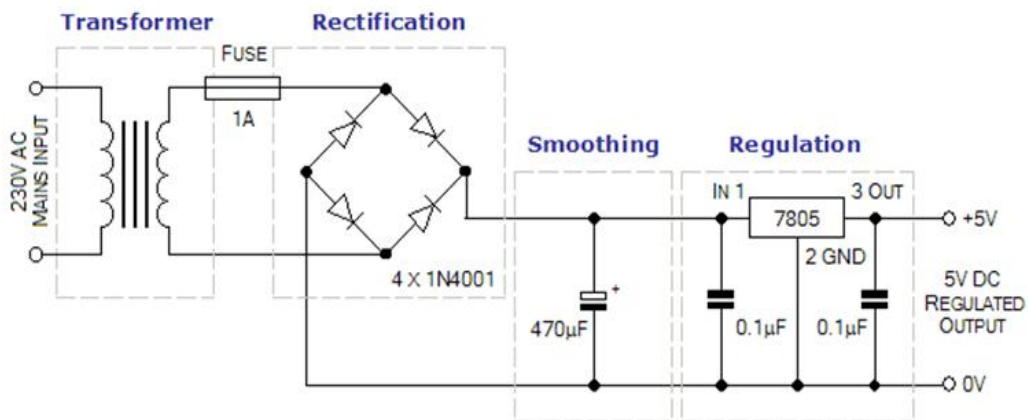

Fig. 6. The system power supply circuit

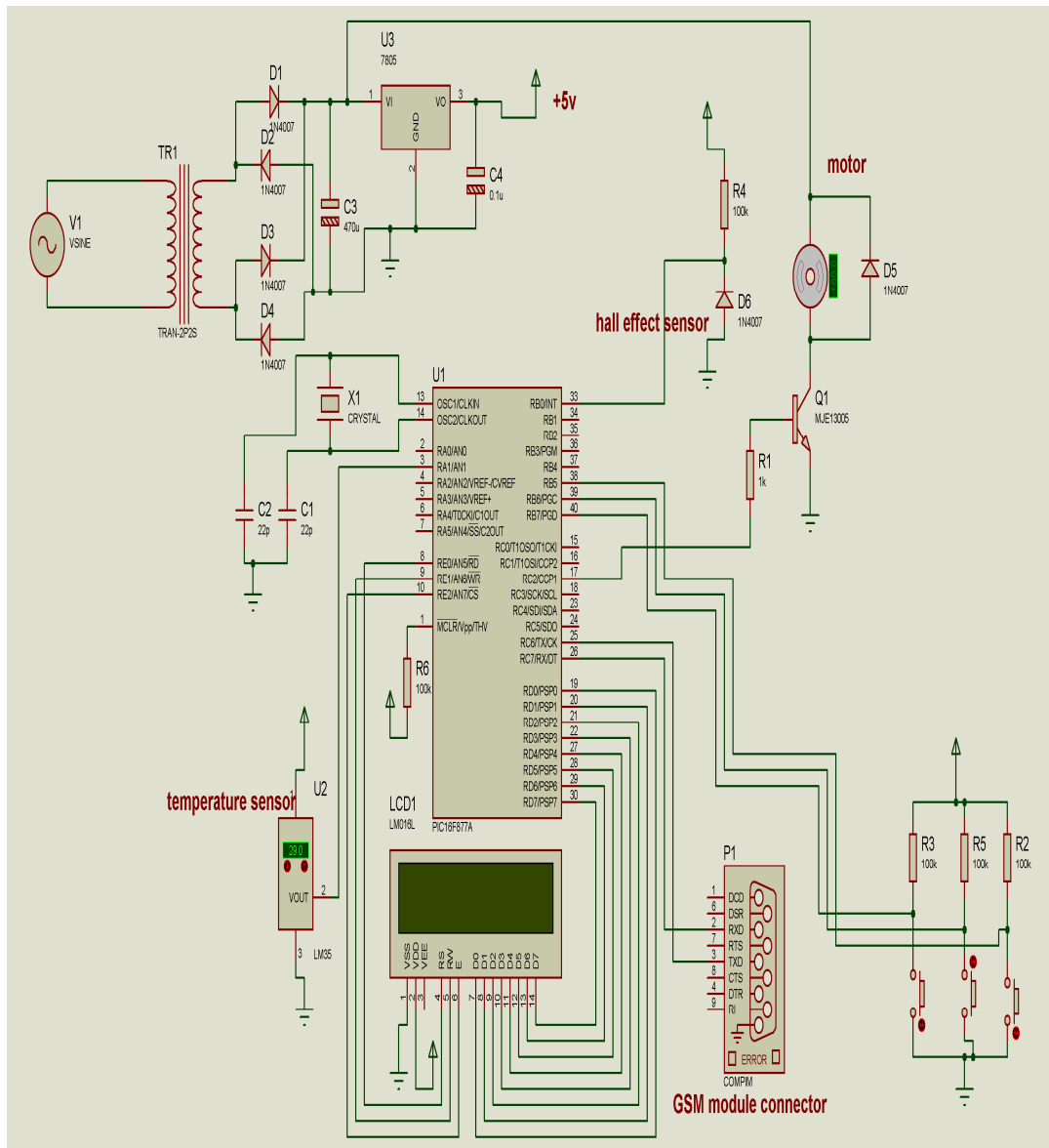

Fig. 7. The circuit diagram

3.4 The GSM Interface Result

The microcontroller sends AT command to the GSM module so as to configure it to be able to send SMS. The results of these configurations are displayed on the device LCD as the configuration proceeds. The configuration completes with the GSM module being connected to the GSM network.

Then as the motor input parameters of temperature and RPM varies, this information is equally sent as SMS to the plant operator so that

irrespective of his current location, he can be aware of the motor operational parameters.

3.5 Fuzzy Inference and Rule Base Design

Here, the degree of membership of the crisp temperature input value and the crisp motor rpm input value are determined using the inference system; it also checks for the rule that is activated and then computes the output based on the active rule.

The degree of membership is given by checking the value of the input temperature and rpm and getting the extent to which, it belongs to the different membership functions.

In computing the degree of membership of the crisp input using the triangular MF, the Side-Side-Side postulate for similar triangles is invoked. The expression used in computing the degree of membership for the linguistic variable is given thus –

$$\text{(Crisp input)}^{MF} = \frac{MF_{\max} - \text{crisp}}{MF_{\max} - MF_{\text{centre}}} \text{ for } MF_{\text{centre}} < \text{crisp} \quad 3.1$$

$$\text{(Crisp input)}^{MF} = \frac{\text{Crisp} - MF_{\min}}{MF_{\text{centre}} - MF_{\min}} \text{ for } MF_{\text{centre}} > \text{crisp} \quad 3.2$$

Where each MF is defined by 3 values i.e. MFmin, MFcentre and MFmax (representing the position of the three vertices of the triangular MF). Crisp is the numerical value undergoing fuzzification.

For example, assuming the crisp input temperature is 34°C. this falls between WM and HT membership functions.

From equation 3.12,

$$(34)^{WM} = \frac{35-34}{35-30} = 0.2 = 20\% \quad \because 30 < 34$$

From equation 3.13

$$(34)^{HT} = \frac{34-33}{39-33} = 0.167 = 16.7\% \quad \because 39 > 34$$

From the foregoing, crisp temperature input will have 2 fuzzy values. In this scenario, 34°C is 20% WARM and 16.7% HOT.

The memberships gotten for both temperature and rpm kick in the rule base which is used to adjust the PWM for controlling the rotor. If temperature rises while motor RPM is low, embedded fuzzy modifies PWM to adjust motor current; motor speed varies and the motor RPM reflects the adjustment.

There are only two inputs hence the rule base is simple and is as shown below.

if temperature is CO and rpm is VL then pwmcurrent is VHI

if temperature is CO and rpm is L then pwmcurrent is HI
 if temperature is CO and rpm is OK then pwmcurrent is OK
 if temperature is CO and rpm is HI then pwmcurrent is LO
 if temperature is CO and rpm is VH then pwmcurrent is VLO
 if temperature is WM and rpm is VL then pwmcurrent is HI
 if temperature is WM and rpm is L then pwmcurrent is OK
 if temperature is WM and rpm is OK then pwmcurrent is OK
 if temperature is WM and rpm is HI then pwmcurrent is LO
 if temperature is WM and rpm is VH then pwmcurrent is VLO
 if temperature is HT and rpm is VL then pwmcurrent is OK
 if temperature is HT and rpm is L then pwmcurrent is HI
 if temperature is HT and rpm is OK then pwmcurrent is OK
 if temperature is HT and rpm is HI then pwmcurrent is LO
 if temperature is HT and rpm is VH then pwmcurrent is VLO
 if temperature is VHT and rpm is VL then pwmcurrent is LO
 if temperature is VHT and rpm is L then pwmcurrent is LO
 if temperature is VHT and rpm is OK then pwmcurrent is LO
 if temperature is VHT and rpm is HI then pwmcurrent is VLO
 if temperature is VHT and rpm is VH then pwmcurrent is VLO

The microcontroller can easily handle these rules because they are not so numerous.

3.6 Design of Fuzzy Membership Functions (Mf)

This design was done essentially with the fuzzylite software. This system comprises of two inputs - the temperature and motor RPM and one output, the PWM controlled current.

3.6.1 Temperature input membership function

For the linguistic variable Motor Temperature, the range of values used is 0 to 100°C and is grouped into 4 fuzzy values shown in Table 1.

Table 1. Fuzzy values of the temperature

S/no	Motor temperature (°C)	Fuzzy classification	Linguistic acronym
1	0 – 30	COOL	CO
2	25 – 35	WARM	WM
3	33 – 45	HOT	HT
4	40 and above	VERY HOT	VHT

These values were plotted on the fuzzy lite software; the degree of membership of the fuzzy values (CO, WM, HT, VHT) is scaled on a 0 to 1 reference. These values are provided by the temperature sensor LM35.

Fig. 8 shows the mapping of the Fuzzy variables into membership functions using the triangular membership function for a typical operating point of 34.1°C as provided by the software platform.

3.6.2 Motor rpm input membership function

For the linguistic variable Motor RPM, the range of values used is 1 to 999 rpm and it is grouped into 5 Fuzzy values shown in the table in Table 2 below.

These values were plotted on the fuzzy lite software; the degree of membership of the fuzzy values (VL, L, OK, HI, VH) is scaled on a 0 to 1 reference. These values are provided by the Hall Effect sensor A1101.

Fig. 9 shows the mapping of the Fuzzy variables into membership functions using the triangular membership function for a typical operating point of 407RPM as provided by the software platform.

3.6.3 Output membership function

The motor specification is 12V, 2W.

The supplied voltage is 15V.

This means that motor draws 0.167A from power supply. Also, since supplied voltage is bigger than motor specification voltage, PWM control having a variable duty cycle is used to supply to the motor its power supply specification and it follows thus –

$$V_{out} = V_{in} * \text{Duty Cycle} \quad 3.3$$

Hence

$$\text{Duty Cycle} = V_{out} / V_{in}$$

Where

$$V_{out} = \text{motor specified voltage} = 12V$$

$$V_{in} = \text{supplied voltage} = 15V$$

$$\text{Required Duty Cycle} = 12/15 = 0.8 = 80\%$$

The output function, PWM controlled current varies the duty cycle of the PWM controlling the current. The linguistic variable PWMcurrent, which is the output variable has 5 classifications shown in the Table 3.

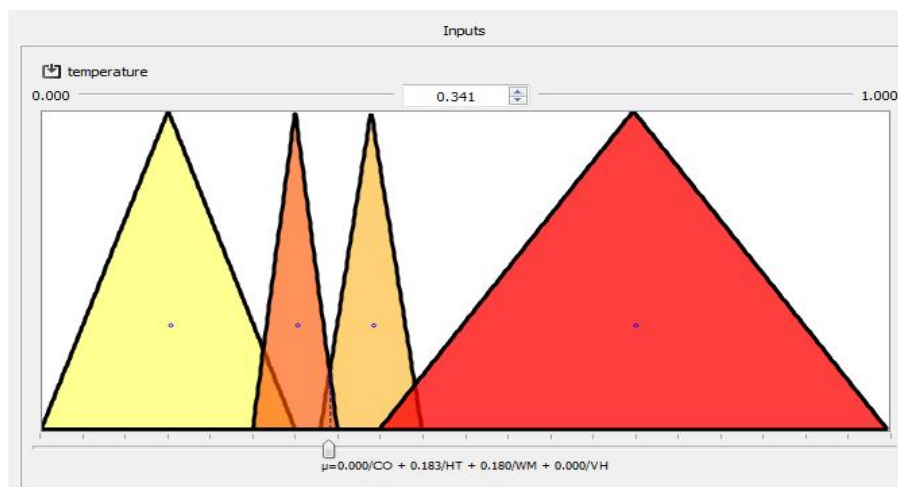

Fig. 8. Fuzzy lite depiction of the temperature MF with an input of 34.1°C

Table 2. Linguistic values of the motor rpm

S/no	Motor RPM	Fuzzy classification	Linguistic acronym
1	1 – 200	VERY LOW	VL
2	175 – 410	LOW	L
3	400 – 600	OK	OK
4	580 -750	HIGH	HI
5	700 – 999	VERY HIGH	VH

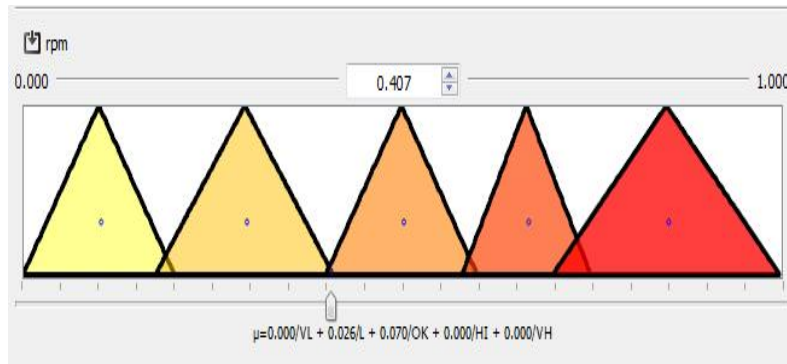

Fig. 9. Fuzzy lite depiction of the motor rpm MF with an input of 407RPM.

Table 3. Linguistic values of the PWMCurrent

S/no	PWMCurrent duty cycle (%)	Fuzzy classification	Linguistic acronym
1	25 – 45	Very low	VLO
2	45 – 60	Low	LO
3	60 – 85	OK	OK
4	85 – 95	HIGH	HI
5	95 – 99	VERY HIGH	VHI

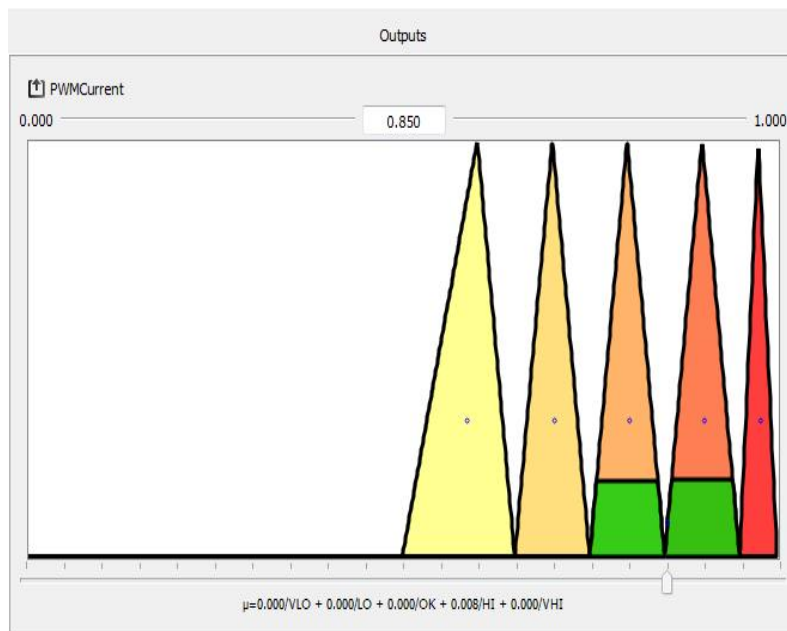

Fig. 10. Fuzzy lite depiction of the PWMCurrent output MF showing 2 members of the output MF (OK and HI) on green colour

These values were plotted on the fuzzy lite software; the degree of membership of the fuzzy values (VLO, LO, OK, HI, VHI) is scaled on a 0 to 1 reference. These values are provided by the PWMCurrent signal used to control the motor current.

Fig. 10 shows the mapping of the Fuzzy variables into membership functions using the triangular membership function for a typical two member of the output MF (OK and HI) as provided by the software platform.

4. RESULTS AND DISCUSSION

Different tools were employed in the hardware design of this system. These tools and their uses were mentioned in section 3.2; thus, here the examination of the results from the utilization of these tools shall be explored. Also, a prototype was constructed. Parameters from the prototype were measured and compared with results from the hardware design simulations tools.

The GSM module was equally configured for seamless operation as it effectively connected to the network and sends SMS to the predefined phone number.

4.1 GSM Interface Result

The microcontroller sends AT command to the GSM module so as to configure it to be able to send SMS. The results of these configurations

are displayed on the device LCD as the configuration proceeds. The configuration completes with the GSM module being connected to the GSM network.

Then as the motor input parameter of temperature and RPM varies, this information is equally sent as SMS to the plant operator so that irrespective of his current location, he will be aware of the motor operating condition.

4.2 Simulation Result from Proteus

Proteus is used to test the hardware as designed in section 3.1, while the embedded program written in MPLAB is being executed. The temperature sensor here is the LM35 sensor as designed. RPM pulses are generated with a NE555 timing chip. This is because Proteus does not directly measure RPM. An LCD is also provided for visualization of measured parameters. The microcontroller used is the PIC16F877A which executes the embedded fuzzy algorithm.

At a temperature of 29°C and rpm of 450, PWM output as measured by the oscilloscope is 50%.

4.3 Simulation Result from Fuzzy Lite

This hardware design tool was used to simulate the different membership functions of the temperature input and RPM input.

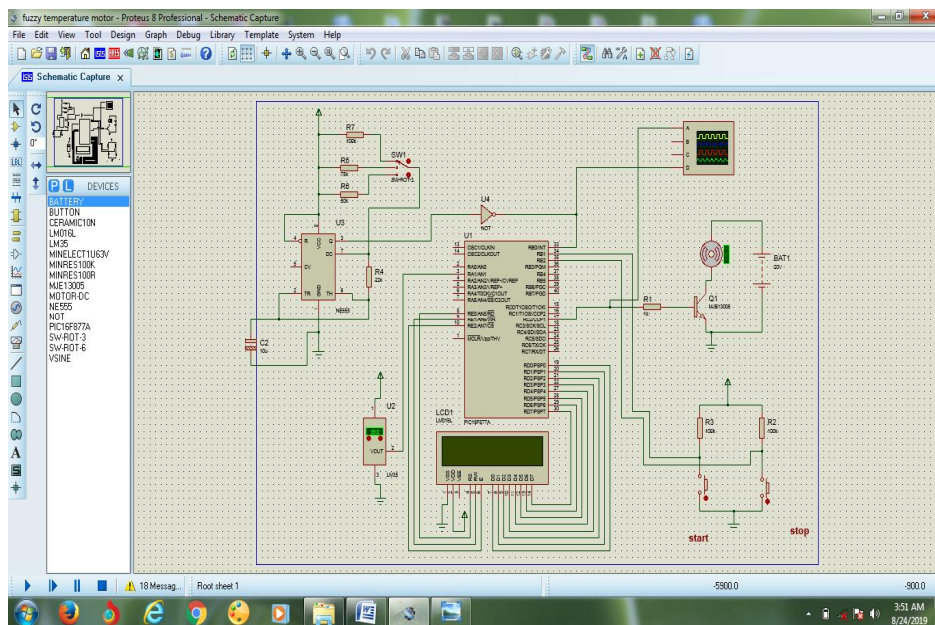

Fig. 11. The proteus simulation setup

The temperature values and instantaneous motor RPM values obtained were fed into the fuzzy lite tool. The de-fuzzified output (PWM) is used to control the motor current through the feedback system.

The motor input temperature ranges from 1° to 100° while the RPM ranges from 1rpm to 999rpm. Different combinations of these are fed into the fuzzy lite tool and different rules will be fired such that no one single if- then statement determines the output. Mean of max (MOM) approach is employed for the defuzzification and the defuzzified PWM output is used to produce a PWM current to control the motor such that its operating characteristics are within the normal range.

Table 4 above show the values from temperature and speed sensors use to generate PWM duty

cycle. The temperature value and the speed of the motor from the sensor are fed into a Fuzzy Lite function which generates PWM having a duty cycle of the specified percentage.

Fig. 12 shows an input temperature of 34.1° which fired WM and HT of the membership function and an RPM of 507 which fired the OK membership function. This led to output membership function of OK being fired, generating a PWM signal of 80% duty cycle.

With an input temperature of 41.7° which translates into 2 members HT and VHT and an RPM of 407 which translates into 2 member's L and OK. These crisp input combinations caused the output members OK, HI and VHI to fire; generating a PWM output of 76.9% duty cycle as shown in Fig. 13.

Table 4. Simulation result from Fuzzy Lite

S/N	Temperature (°)	RPM	PWM (duty cycle)
1	34.1	507	80
2	41.7	407	76.9
3	45	376	52.5

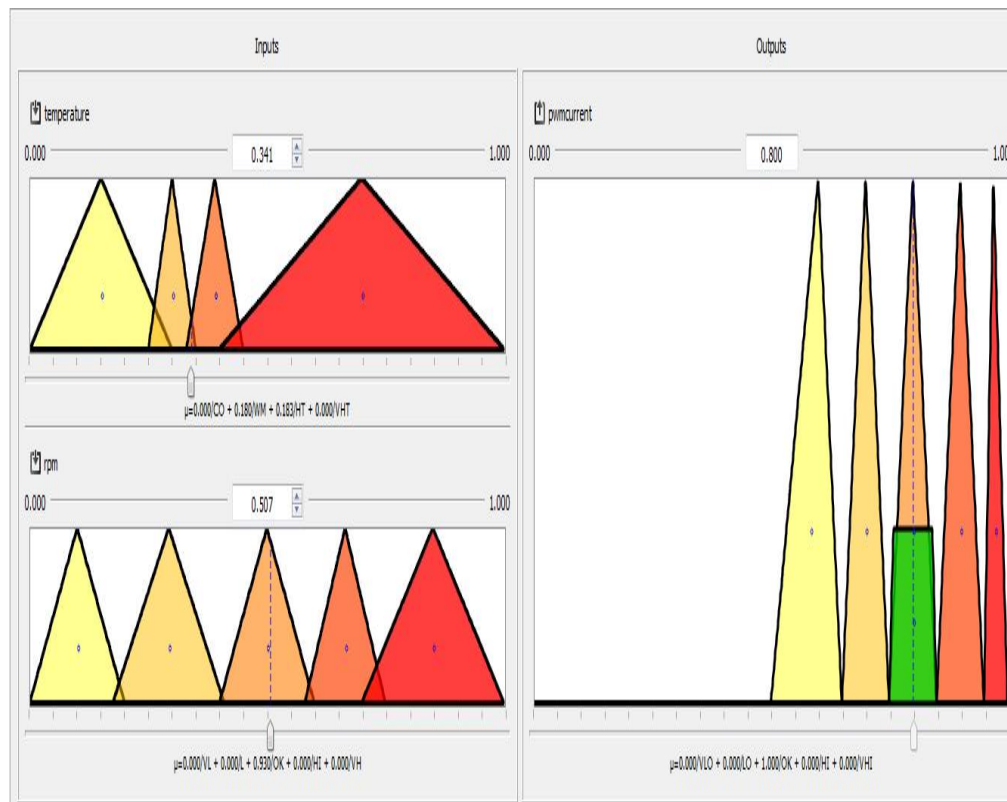

Fig. 12. Fuzzy lite 34.1° input and 507 rpm input simulation result

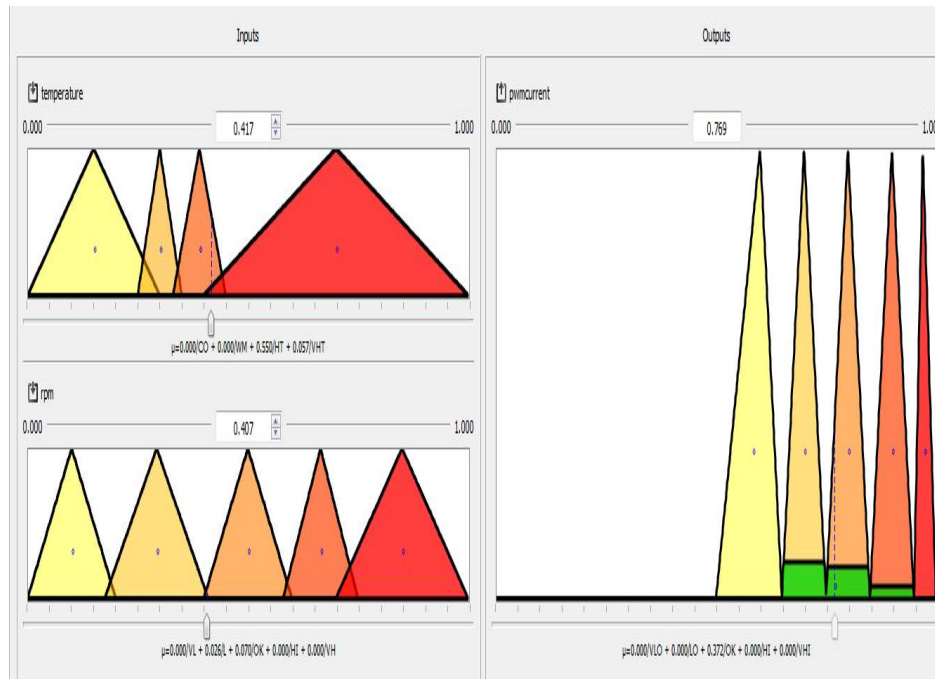

Fig. 13. Fuzzy lite 41.7degree input and 407 rpm input simulation result

Given the extreme operating conditions of 45° and low rpm of 376 fed into the fuzzy lite tool, appropriate output membership function of OK fired, generating a 52.5% duty cycle PWM signal as shown in Fig. 14.

The figure above shows the pwm output result when the temperature input value is at 45°C and the motor rpm is at 376.

4.4 Comparative Analysis of Bell-shape and Triangular Membership Function

As the system is in operation, the operating parameters will vary; this will equally result in the variation of the output parameter. Here the triangle method is compared with the bell method. These parametric variations are captured in both methods and their results compared.

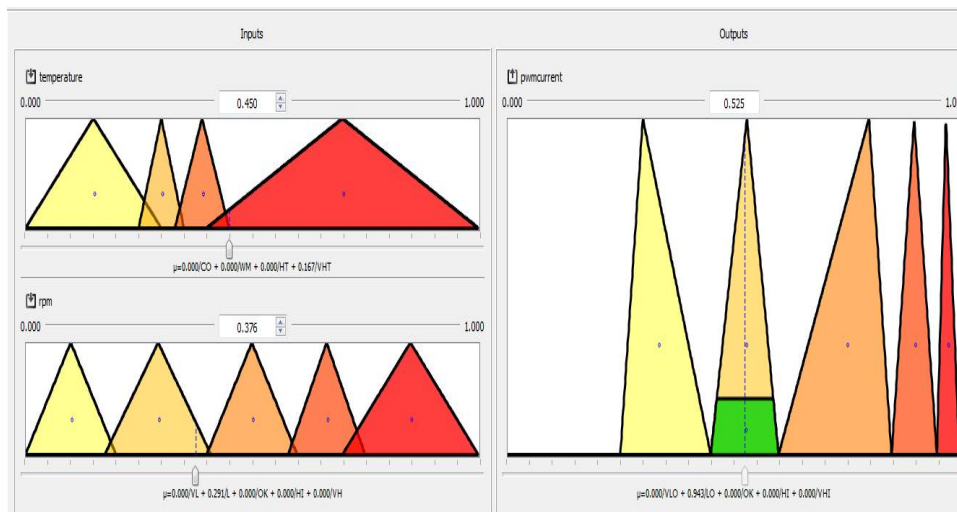

Fig. 14. Fuzzy lite 45-degree input and 376 rpm input simulation result.

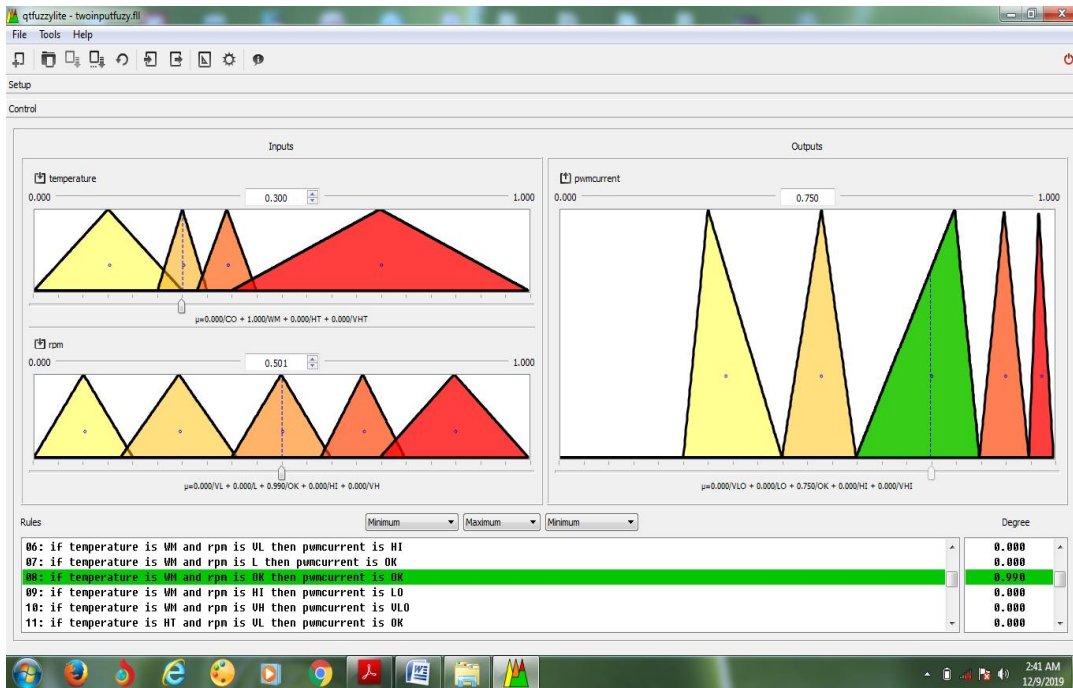

Fig. 15(a). Triangular method when the temperature is warm and RPM is OK

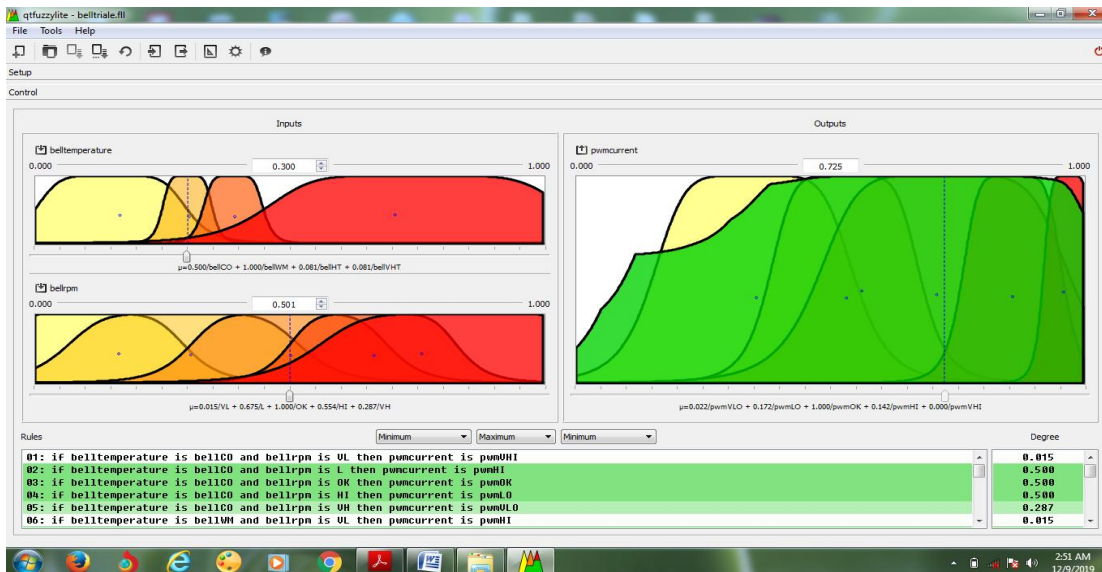

Fig. 15(b). Bell method when the temperature is warm and RPM is OK

As is seen in Figs. 1 and 2 above, there is overlap in both input membership functions but the overlap in bell method is more extensive. Also, in the bell method, more rule base fired for the same overlap reason.

The output parameter pwmcurrent is 0.750 for the triangular method but it is 0.725 in the bell

method. This variation is minimal being that both values are within the same output membership function.

In conclusion, while the triangular method has overlap in the input membership functions, the overlap in the bell method is broader. This results in more rule base firing in the bell method as

compared to the triangle method. But their output parameter result is still within range because their de-fuzzification procedure is the same.

5. CONCLUSION

This project having been designed and developed to meet the aims and objective as specified which include: -

- Investigating the relationship between temperature of the rotor of an electrical motor and the motor rpm.
- Designing a fuzzy logic controller to control the motor using temperature and motor rpm as crisp input to the fuzzy system.

It is obvious that the prototype delivered exceptionally well as compared with what is simulated.

5.1 Challenges/Problems Encountered

The development of this article did not go without problems. Unique challenges arose because of the uniqueness of the simulations required for the implementation of the project. However, some challenges faced were generic.

The first challenge was sourcing pertinent and critical fuzzy logic simulation integrated development environment. Most of the good applications available online were very expensive to buy. It took several weeks of searching before the fuzzy lite software was found. The software proved to be as good as the expensive ones even though it was more affordable. Next, it was pertinent to learn to navigate through the software.

In addition to that, getting the exact sensors used in the design was a daunting task as the LM35 temperature sensor was not available in the local market. It had to be ordered from China using alibaba.com

During the construction of the prototype, power failure was an everyday experience. A Standby petrol generator was used as a power back up.

5.2 Further Research Work

This research work uses Mean of Max defuzzification method, future research work should use Centroid method to see the response of the microcontroller. It will extend the application of fuzzy controller and probably

improve performance. Hence, this work is subject to more research and development with a view to come up with a better system.

ACKNOWLEDGEMENT

Author 1 design the study, generate the membership function, wrote the protocol and run all the simulations. Author 2 manage the analysis of the study. Author 3 manage the literature review search of the study. All the author read and approved the final manuscript. Study sponsor had no funding.

COMPETING INTERESTS

Authors have declared that no competing interests exist.

REFERENCES

1. Ying Bai, Hanqi Zhuang, Dali Wang. Advanced fuzzy logic technologies in industrial applications. Springer-Verlag London; 2006.
2. Zadeh LA, et al. Fuzzy sets, fuzzy logic, fuzzy systems. world scientific press; 1996. ISBN 978-981-02-2421-9.
3. Nagrath I, Gopal M. Control systems engineering. 2007;784-790. Available:<https://www.newagepublishers.com>
4. Wartsila. Gas turbine for power generation nwodoh; 2009.
5. Thomas A, Ejimofor Ihekeremma A. Implementation of fuzzy logic-based temperature-controlled, Nigerian journal of technology; 2010.
6. Bamidele Idiong, Chukwunazo Ezeofor. GSM based power plant temperature remote monitoring and control system with real time data acquisition. International Knowledge sharing platform; 2017. Available: www.iiste.org
7. Okan Uyar. Fuzzy logic-based induction motor protection system, Selcuk University; 2012. Available:<https://www.researchgate.net/publication/257435276>
8. Awodele Oludele, Olamide Kalesanwo FY, Osisanwo. Performance evaluation of some mobile adhoc network routing protocols, performance evaluation of some mobile adhoc network routing protocols. 2nd International Conference on Intelligent Computing and Emerging Technologies ICET; 2016.

- Available: <https://www.researchgate.net/publication/311102100>
9. Singh Tarundeep. What is the function of an electric motor, and what benefits does it have? India; 2017.
Available: <https://www.quora.com>
 10. Surti Ammar, Ruting Jia, Wenyuan Xiao. Control of gas turbine's speed with a fuzzy logic controller. Proceedings of the 2015 ASEE Gulf-Southwest Annual Conference. Electrical and Computer Engineering Department, University of Texas at San Antonio; 2015.
 11. Engin Yesil, Aysen Demiroren, Erkin Yesil. Automatic generation control with fuzzy logic controller in the power system including three areas. Department of Electrical Engineering, Electric and Electronic Faculty Istanbul Technical University, 80626 Maslak, Istanbul, Turkey; 2013.
 12. Alheraish A. Design and implementation of home automation system. IEEE Transactions on Consumer Electronics. IEEE Transactions on Consumer Electronics; 2004.
 13. Fanjie Wei. The PLC-based industrial temperature control system: Design and implementation, MATEC web of conferences. Chongqing College of Electronic Engineering, No. 76, Eastern Road, Daxuecheng, Shapingba District, Chongqing, 401331, China Shankar 2009. Remote monitoring system for distributed control of industrial plant process. Journal of scientific and industrial research; 2017.
 14. Nagabhushana Katte, Nagabhushan Raju Konduru, Bhaskar Pobbathi, Parvathi Sidaraddi. Fuzzy logic applied to an oven temperature control system. Sensors and Transducers Journal. Anantapur, India; 2011.
 15. PCB-3D. DC motors - Basic characteristics and mathematical model; 2019.
Available: <https://www.pcb-3d.com/tutorials/basic-characteristics-and-mathematical-model-of-a-dc-motors/>
 16. Arvind Jayashri, Abhishek. Implementation of home security system using GSM module and microcontroller. International journal of smart home; 2015.
 17. Lei Lei Hnin, U Zaw Min Min Htun, Hla Myo Tun. Fuzzy logic temperature control system for the induction furnace. International journal of scientific and technology research. 2016;5(06):2277-8616.
Available: www.ijstr.org
 18. Surti Ammar, Ruting Jia, Wenyuan Xiao. Control of gas turbine's speed with a fuzzy logic controller. Electrical and Computer Engineering Department California State University, Northridge, Electrical and Computer Engineering Department, The University of Texas at San Antonio; 2015.
 19. Singhala P, Shah DN, Patel B. Temperature control using fuzzy logic. Department of instrumentation and control, Sarvajanik College of Engineering and Technology Surat, Gujarat, India; 2014.

© 2021 David et al.; This is an Open Access article distributed under the terms of the Creative Commons Attribution License (<http://creativecommons.org/licenses/by/4.0>), which permits unrestricted use, distribution, and reproduction in any medium, provided the original work is properly cited.

Peer-review history:

The peer review history for this paper can be accessed here:
<http://www.sdiarticle4.com/review-history/67456>